



HD 3DM-ControllerCamera

Controllable camera unit for VideoFlex HD with a 1-meter probe and a small, highly maneuverable camera head – provides maximum flexibility for complex tasks and is ideal for small openings

This controllable camera unit for VideoFlex HD, equipped with a 1-meter probe, offers maximum flexibility for complex tasks and is ideal for small openings. The camera head can be quickly adjusted to the optimal angle using a joystick, allowing the inspection of hard-to-reach areas that are not visible with rigid camera systems. Inspections are highly reliable, with the ability to check components like pipe seals at 360° and precisely identify damaged areas. Thanks to magnetic stands, the camera unit and compatible base unit can be freely positioned, leaving the user's hands free to work. The camera head and probe are waterproof and resistant to diesel, gasoline, motor oil, AdBlue®, ethanol, and saltwater, making the device versatile for various applications. Premium illumination with eight high-performance LEDs ensures clear and detailed imaging, even in challenging lighting conditions.

TECHNICAL DATA

Diameter Camera Head	6 mm
Camera Resolution	1280 x 720 pixels
Field of View (FOV)	78
Depth of Focus (DOF)	3 ... 8 cm
Length of Probe	1 m
Ports	Industrial connector for camera
Dimensions (W x H x D)	190 mm x 145 mm x 88 mm
Weight	450 g #

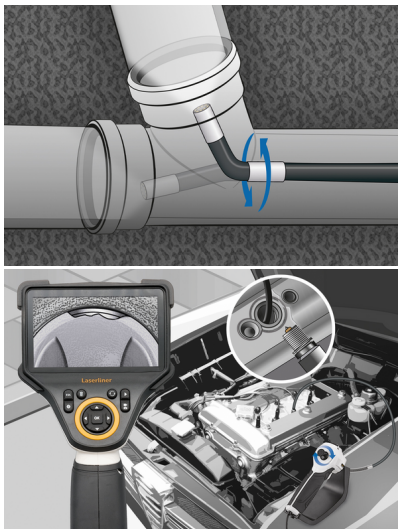

- Controllable camera unit for the VideoFlex HD
- Joystick control of the camera head provides maximum flexibility and optimum viewing
- Save time setting up on site with rapid adjustment of the required viewing angle
- Perfect for hard to reach locations which cannot be viewed with fixed camera systems
- Reliable 360° inspection of pipe seals

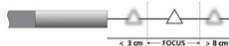

SCOPE OF DELIVERY



Item No. 082.286A GTIN (EAN) 4021563732487 SU 1